

ENERGY SAVINGS KIT (HESK120V, HESK220V)

1. Application

The Vtronix Energy Savings Kit reduces energy consumption by sending a dry contact signal to a digital thermostat to change its set-point (increase in cooling mode) when the room is not occupied. Alternatively, it can also turn off the line voltage input to the air conditioner. The control board utilizes a Passive Infrared (PIR) Detector and a Door Sensor to determine the room status. When the room is not occupied, it will enter power savings mode to reduce energy consumption.

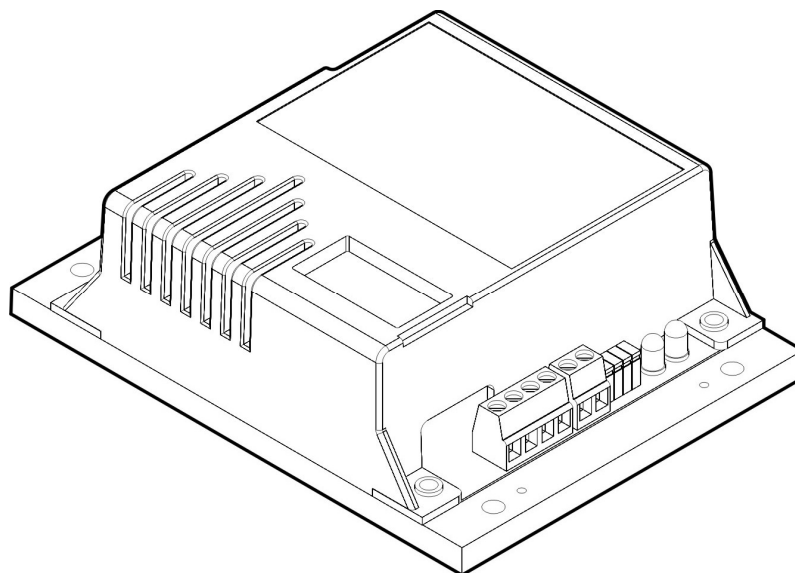

Figure 1. Product picture.

Table 1. Control board specifications.

Power	
Input Power Supply	120, 220 VAC (+20/-20%), 50/60 HZ (by model)
Power Consumption	4VA maximum
Output Power to PIR sensor	14-10 Vdc, 15mA Maximum
PIR Motion Detector	
PIR detector with N.O. or N.C. contacts	12 VDC power
Components	
Magnetic door contacts (2 sets)	Included with 18 inch wire leads, set to operate as closed contacts for closed door.
- Main Door	
- Optional Sliding Door / Window	
Electrical Rating	
Energy Savings Relay 1 Mini-split app Relay 1 rating	N.C. contacts cycles in energy savings mode 10 A continuous at 240VAC (resistive)
Energy Savings Relay 2 - Fancoil app Relay 2 rating	N.C. contacts opens in energy savings mode 3 A continuous at 240VAC (resistive)

2. Dimension

W 3 ¾ x D 3 ¾ x H 1 ¾ Inches

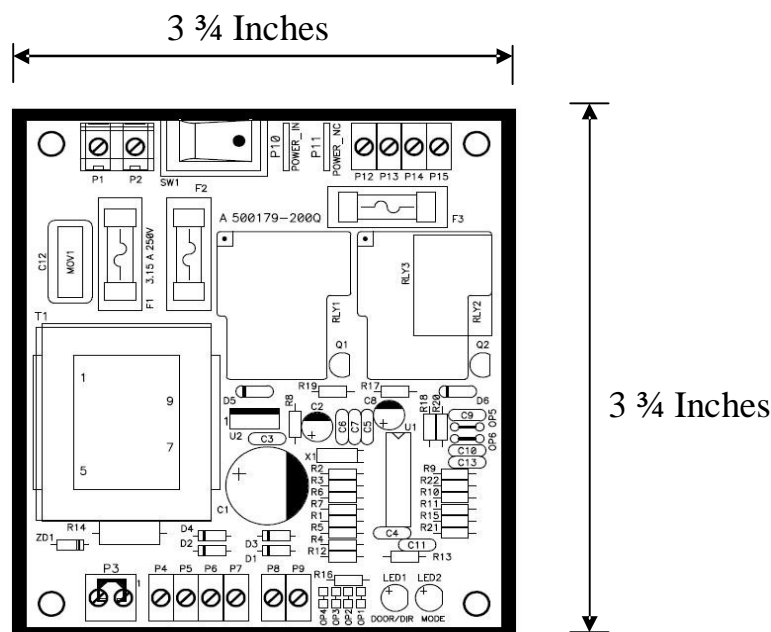

Figure 2. Control board Dimension.

3. System Operation

3.1 Motion Detection

Front Door Closed

When the room guest enters or exits the room (after the door is closed) the door sensor will send a signal to the control board to enter PIR detection mode. If the PIR sensor can detect movement within 15 minutes, the system will work in normal mode, i.e., no signal is sent to the thermostat – Energy Savings Relays 1 and 2 NC contacts are closed. If no motion is detected in 15 minutes, the system will enter the energy savings mode, a contact open signal is sent to the thermostat, to reduce energy consumption Energy Savings Relay 2 NC contacts are open. For mini-split applications, Energy Savings Relay 1 NC contacts will open and close to cycle the power (30 minutes on / 30 minutes off OR 15 minutes on / 45 minutes off) depending on jumper option 4. While in the energy savings mode, if the PIR detector senses motion, the controller will immediately revert back to normal operation and return the thermostat or mini-split to normal operation.

The system will continue to be in the energy savings mode indefinitely until the front door is opened or the PIR detector detects motion.

Note that the system is meant to go into energy savings mode only when the room is unoccupied. It is not intended to have this mode active when the guest is in the room or the room is being serviced.

Front Door Open

If the front door goes from closed to open position, the system will go to normal mode, i.e. no signal is sent to the thermostat or mini-split resumes normal operation.

12 Hour Option

After 12 hours of continuous no motion detected by the PIR, regardless of door status, the system will switch to energy savings mode. If the PIR detector senses motion, or the front door goes from closed to open position, the system will revert to normal mode. This feature can be turned OFF by removing jumper on OP3.

3.2 Sliding Door / Window (optional)

The control board provides extra terminals for connection to an optional sliding door or window switch. This should be set for opening when the sliding door or window opens. If this is connected, when the balcony door or window is opened, a dry contact signal is sent to the thermostat

Switch contacts are opened. Note that the control board itself does not recognize or act upon a sliding door switch opening. It is not required for the installer to use this feature. A factory installed jumper is provided in case this feature is not used.

3.3 Test Mode

The test mode is for testing the product during installation to make sure the door contacts and PIR motion detector are operating correctly. During the test mode, the occupancy detection mode is shortened to 1 minute and the cycling mode of Energy Savings Relay 1 is set for 1 minute on and 1 minute off.

3.4 System Options

Table 2. System Option.

Option	Description	Jumper Removed	Jumper Installed (factory default)
OP1	PIR output type (normally open/closed)*	NO	NC
OP2	Test MODE	Test mode	Normal mode
OP3	12 Hour Option	Off	On
OP4	ES Relay 1 Cycle timer (ON/OFF) **	30/30 Min	15/45 Min

NOTE: Turn off power to system before changing jumper options.

* Normally Closed PIR means PIR sensor will open on motion detection.

** In this case ES Relay 1 will be energized as per cycle On and Off times for mini-split applications.

Jumper Removed: Relay energized for 30 minutes and relay de-energized for 30 minutes.

Jumper Installed: Relay energized for 45 minutes and relay de-energized for 15 minutes.

This means Relay 1 contacts are open for 45 minutes and closed for 15 minutes.

3.5 Bypass Switch

The bypass Switch is intended to bypass the control board and return the thermostat back to normal operation immediately. This is meant to be used by the hotel maintenance staff in case of any problems or emergencies.

3.6 LED Indicators

These LEDs are provided for system status and troubleshooting

Door/PIR LED Indicates door switch and PIR detector activation (RED COLOR)

- LED on for 4 seconds means the door switch is closed
- LED flashing twice means PIR detector senses motion

Mode LED Indicates energy savings mode (GREEN COLOR)

- LED on means the system is powered
- LED flashing means system is in energy savings mode
- LED off means the system has no power

Warning:

1. **On initial power up, a PIR sensor can take up to 1 minute to stabilize before it senses motion.**
2. **There is a 30 second delay time at initial power up before the Energy Savings Kit senses motion from the PIR sensor. This is to prevent sensing an unstable signal generated by the PIR sensor. This delay time is bypassed during the test mode.**

4. Wiring Diagram

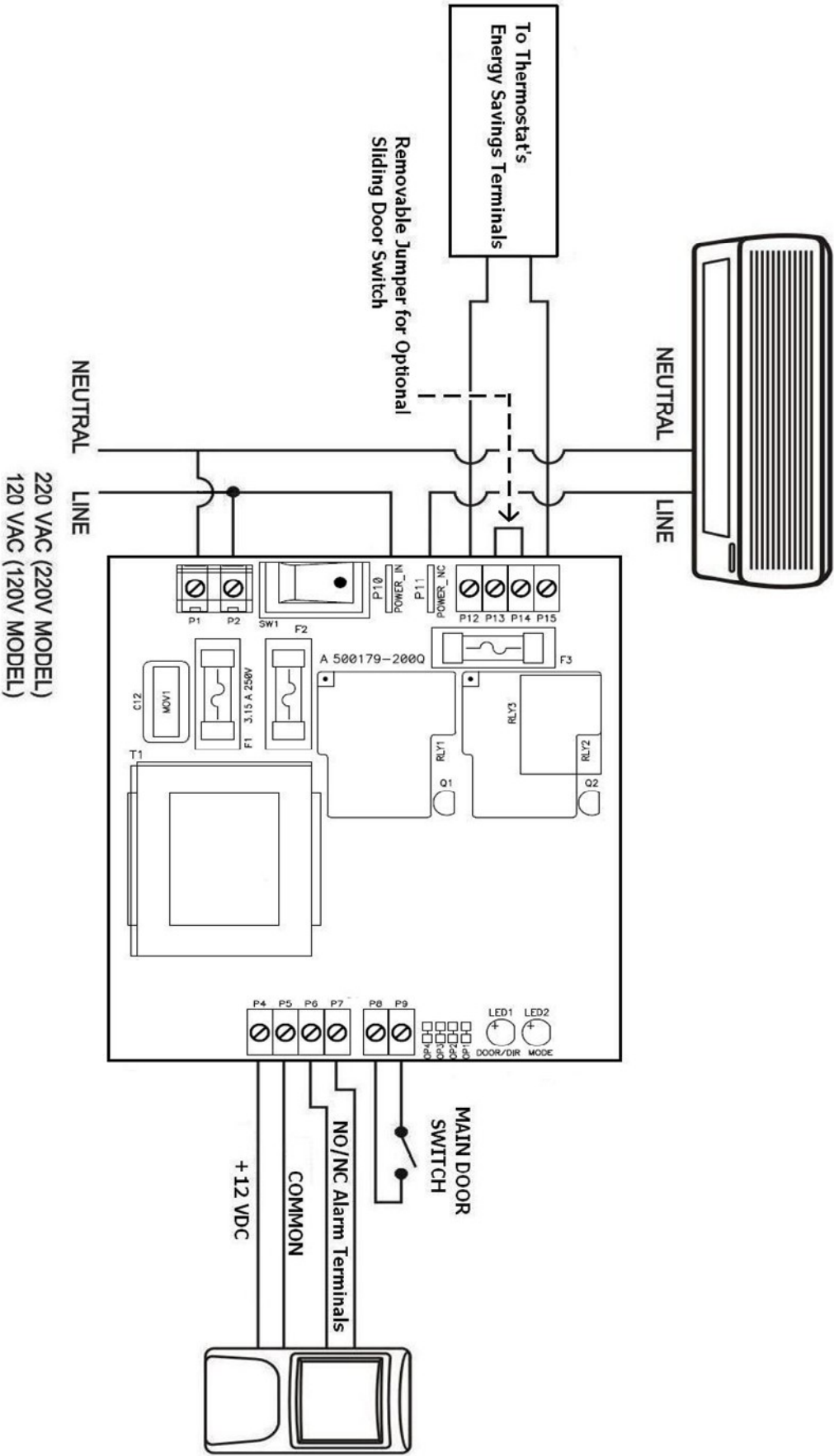

Figure 3. Wiring Diagram.

This page is intentionally left blank

This page is intentionally left blank

