

# **FUNCTIONAL SPECIFICATIONS**

**For**

**AIR CONDITIONING CONTROLLER**

**Applied to**

**AIR CONTROLLER**

**SMALL BOARD COOL ONLY (M12)**

\_\_\_\_\_

\_\_\_\_\_  
CUSTOMER APPROVAL  
\_\_\_\_\_

\_\_\_\_\_

BY

DATE

**1. GENERAL**

The following describes the features and functional specifications of AIR CONTROLLER M12 COOL ONLY

Each set of controller consists of

- ❑ Main unit
- ❑ Wireless display unit + Cable 6 cores (2 M.)
- ❑ Remote LCD5.1/5.2

**Note:** Room sensor (1 M.)

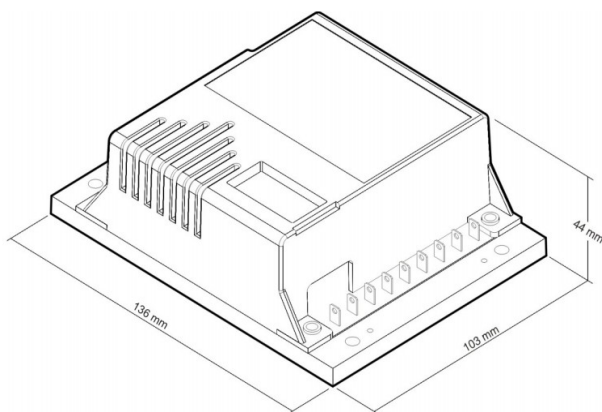

Main unit

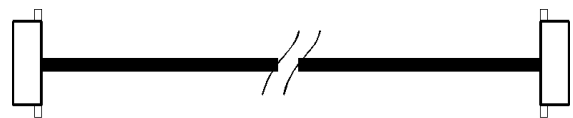

CABLE 6 CORE (2M.)



LCD5.1



LCD5.2

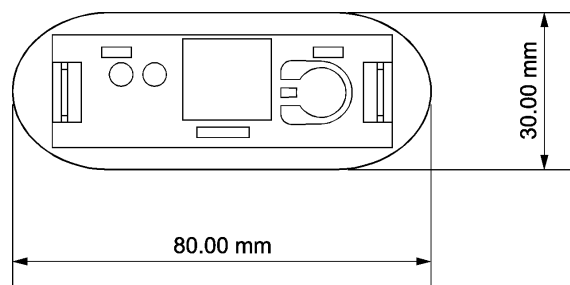

**2. USER’S FEATURES**

The following features can be operated by using the buttons on the Remote unit.

**2.1 Power on/off**

Press ① button will turn on/off the air conditioner. When turn on, it will operate according to the setting shown on the Remote unit.

**2.2 Fan**

Fan 🌀 button to select the fan speed (high, medium, low or auto mode). The display on the Remote unit will show the status.



**Auto mode**

When the fan speed is put in auto mode, the speed will be adjusted automatically according to the difference between the room temperature and setting temperature.

- ❑ If the difference is 3 °C or more, the speed is high.
- ❑ If the difference is 2 °C, the speed is medium.
- ❑ If the difference is 1 °C or less, the speed is low.

**Note:** The Fan 🌀 button can be used only in Fan and Cool mode, it can not be used in Dry mode.

**2.3 Operating mode**

Press **MODE** button on LCD remote to select mode of operation as in diagram below.

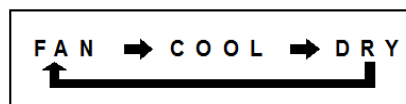

**Fan :** The LCD on the Remote unit will show FAN. The system will operate as the fan only. The SLEEP, TEMPΔ and TEMP∇ buttons are not used.

**Cool :** The LCD on the Remote unit will show COOL. The system will operate as the air conditioner. The compressor will

- ❑ operate if  $T_{room} \geq T_{set} + 1$
- ❑ stop if  $T_{room} \leq T_{set}$

However, the compressor is subjected to 3-minute delay protection each time it stops.

**Dry :** The LCD on the Remote unit will show DRY. The system will operate as the dehumidifier to reduce the humidity in the air.

## 2.4 Temperature setting

Press  button for temperature setting in a range of 18-30 °C.

## 2.5 SWEEP (OPTIONAL)

Press SWEEP button will turn on/off the sweep motor.

## 2.6 Sleep

Press the SLEEP button will start the sleep function. The LCD on the Remote unit will show the ★★ symbol. The setting temperature will be automatically raised up 1 °C after one hour.

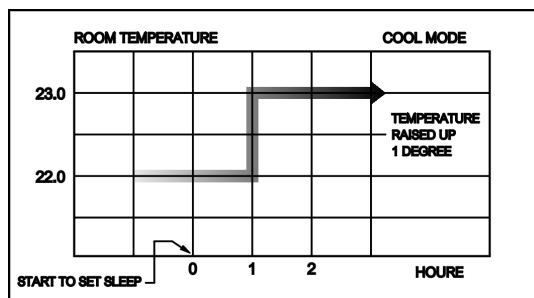



Note:

- When the system is put in the sleep mode, press SLEEP button again will cancel the sleep function.
- When the system is put in the sleep mode and the TEMP  button is pressed, it will raise up the setting temperature 1 °C from the last setting.
- When the system is put in the sleep mode and the air conditioner is stopped by the power failure or by turn off, it will cancel the sleep function.

## 2.7 Clock



To set the clock on the Remote unit is by

- Press  button until the display shows  in blinking,
- Press  button to set the time,
- Press SEND button.

**Note :** If there is no any buttons pressed within 10 seconds, LCD display will return to show setting temperature and no data is transmitted.

## 2.8 Auto start

The air conditioner can be programmed to turn on in advance.

- ❑ Press  button until the display shows ON in blinking,
- ❑ Press  button to set the timer-on,
- ❑ Press SEND button.



To cancel this function

- ❑ Press  button until the display shows ON in blinking,
- ❑ Press CANCEL button.

**Note :** If there is no any buttons pressed within 10 seconds, LCD display will return to show setting temperature and no data is transmitted.

## 2.9 Auto stop

The air conditioner can be programmed to turn off in advance.

- ❑ Press  button until the display shows OFF in blinking,
- ❑ Press  button to set the timer-off,
- ❑ Press SEND button.

To cancel this function

- ❑ Press  button until the display shows OFF in blinking,
- ❑ Press CANCEL button.

**Note :** If there is no any buttons pressed within 10 seconds, LCD display will return to show setting temperature and no data is transmitted.

## 2.10 Send

Press SEND button to transmit all parameters shown on the LCD to the main control board.

## 2.11 Emergency button

There is a emergency button on the Display unit to turn on/off the air condition.

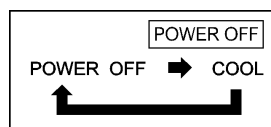

**3. SYSTEM FEATURES**

**3.1 Watchdog**

There is a watchdog circuit to watch the operation of the microprocessor. If it is malfunctioned, this circuit will reset the microprocessor automatically.

**3.2 Compressor delay protection**

Each time the compressor is off, there will always be a 3 minute time delay before the compressor can restart. In case of power interruption, the system will delay the operation of the compressor in the range of 3-4 minutes in random order. This is to protect the compressors in the air conditioners of the whole building start at the same time.

**3.3 Compressor minimum on time**

Once the compress starts, it will operate at least 24 seconds.

**3.4 Non-volatile memory**

The system keeps the setting parameters such as on/off status, fan speed, etc. in its non-volatile memory. If there is a power interruption and back to normal, the control will automatically resume its operation with the same setting parameters (except the sleep and timer function which will be canceled).

If there is any change in the parameter, it will be saved in the non-volatile memory 5 seconds later.

**3.5 Freeze function (optional)**

In Cool or Dry mode, there is a feature to prevent the evaporator from freezing.

Enter into Freeze process	While in Freeze process	Exit from Freeze process
$T_{\text{indoor coil}} \leq 0\text{C}$ , and	Comp. stops, and	$T_{\text{indoor coil}} \geq 7\text{C}$ , or
Comp. runs continuously more than 10 min.	Indoor fan at low speed, and	System OFF
	“POWER” LED blinks	

**3.6 Cooling Fail (optional)**

In COOL or DRY mode if the compressor has been operating more than 3 minutes but the indoor coil temperature is still above  $25^{\circ}\text{C}$ , the compressor is supposed to be failed. There will be an alarm on the Display unit.

To exit from this status is by turning off the air conditioner or changing the mode of operation.

### 3.7 Sensor Error

When the room sensor is failed (open/short circuit), the compressor will be turned on and off in 5 minutes cycle.

When the indoor coil sensor is failed (open/short circuit), the system will operate continuously.

### 3.8 Self diagnostic

There are 2 LEDs ON the Display unit.

**Power** LED shows the ON/OFF status of the air conditioner.

❑ If the freeze (Clause 3.5) protection is active, the **Power** LED will be blinking with the signal as per figure A.

❑ If there is cooling fail (Clause 3.6), the **Power** LED will be blinking with the signal as per figure B.

**Timer** LED shows the status of the auto start (Clause 2.8) and auto stop (Clause 2.9).

❑ If the sensor (room or freeze sensor) is failed due to open/short circuit, the **Timer** will be blinking with the signal as per figure A (Clause 3.7).

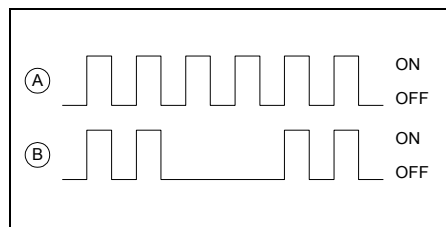

## 4. ELECTRICAL CHARACTERISTICS

<b>POWER SUPPLY</b>	220-240 Vac, 50/60 Hz
<b>POWER CONSUMPTION</b>	Less than 8 VA.
<b>TEMPERATURE:</b>	
Temperature accuracy	±1°C
Storage temperature	0 – 50 °C
Ambient temperature	10 – 40 °C
Setting temperature range	15 – 30 °C
ON/OFF hysteresis temperature	1°C
<b>LOAD CONTROL RELAY:</b> สำหรับความเร็วพัดลม low, medium , high ,compressor	
Rating (resistive load)	
• <i>Rated capacity</i>	7A 240 Vac
• <i>Max. switching power</i>	2,770 VA (AC)
• <i>Max. switching voltage</i>	250 Vac
<b>LOAD CONTROL RELAY:</b> สำหรับ SWEEP	
Rating (resistive load)	
• <i>Rated capacity</i>	5A 250 Vac
• <i>Max. switching power</i>	1,250 VA (AC)
• <i>Max. switching voltage</i>	250 Vac
<b>PROTECTION DEVICE:</b>	
• <i>Fuse</i>	R-Fuse,3.15A,250VAC



**5. WIRING DIAGRAM**

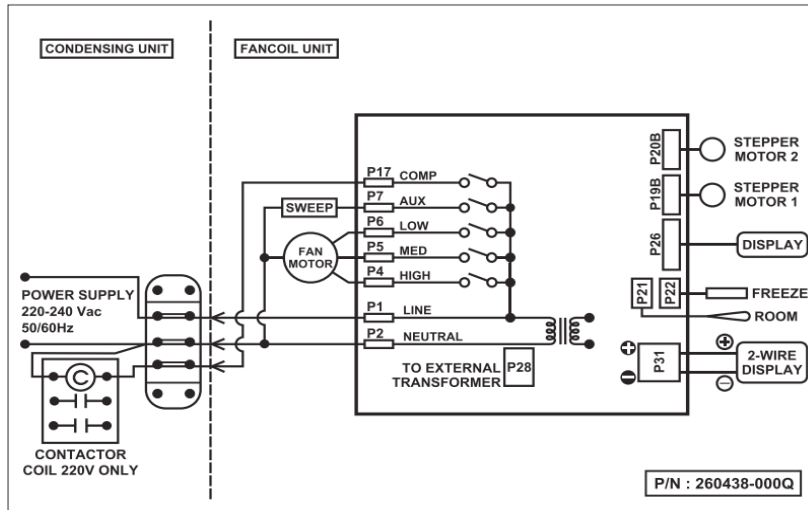

**Note :** High and low voltage wire must be separated to prevent transient voltage from high voltage side.