

SPECIFICATION

APPLICATION

The R200A Series3 AHU control board provides microprocessor control of a hot water or electric heat air handling unit. The board features a jumper select operation between an electric heat system or a hot water system. When selecting an electric heat system, it provides line voltage control of a fan motor or low voltage control of an ECM motor. When selecting a hot water system, it provides line voltage control of a fan motor or low voltage control of an ECM motor, line voltage control of a water pump, 24Vac control for an isolation valve and control of a dry switching relay to turn on/off a water heater. Backwards compatible with 200A (Series 1) and R200A/S2 (Series 2).

Series 3 board has an added relay (RLY4) to provide 24 VAC output to an ECM motor control board. RLY 4 (P31) operation is the same as RLY1 (P7).

Series 3 board has an Aquastat (AQ) input terminal. In Hot Water mode, if the AQ selection jumper is selected to ON, the blower (P7 and P31) is energized only after the AQ input is energized.

Series 3 board has a test connection for production testing.

Figure 1. R200A Board.

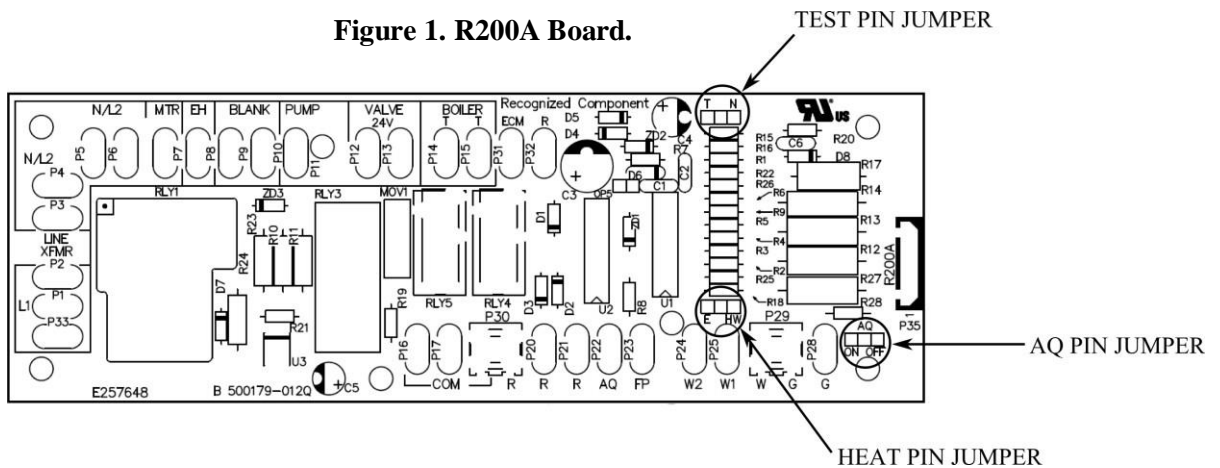

Note: The R200A board must be factory installed and wired inside the equipment it is controlling.

ELECTRIC HEAT FEATURE (HEAT JUMPER SET TO E)

Heating Cycle

1. Electric heat delay: Blower turns on and continues to operate as long as line voltage EH signal is energized and stops the blower operation when EH signal is de-energized. Note that the board does not activate any output when the W (call for heat) signal is energized by the thermostat.

Cooling Cycle

1. Blower-off delay: Blower continues to operate for 45 seconds after G signal is satisfied, extracting more cooling from the cooling coil and increasing cooling efficiency.

HOT WATER FEATURE (HEAT JUMPER SET TO HW)

Heating Cycle

1. Automatic pump timer: The circulating pump automatically energizes four times daily for 60 seconds each cycle (pump timer cycle is skipped while the thermostat G signal is activated).
2. Blower-on delay: If AQ jumper selector is selected to OFF, on a call for heat, the hot water coil is preheated for 60 seconds before the blower energizes. If AQ is selected to ON, on a call for heat, the blower is energized only after the AQ input is energized.
3. Blower-off delay: Blower continues to operate for 30 seconds after the thermostat is satisfied, extracting more heat from the heating coil and increasing heating performance.

Cooling Cycle

1. Blower-off delay: Blower continues to operate for 45 seconds after the thermostat is satisfied, extracting more cooling from the cooling coil and maximizing cooling efficiency.

Optional Features (requires an optional field installed external switch)

1. Freeze protection: Circuit board has FP terminal for optional freeze protector switch. Freeze protector energizes the circulating pump if water coil temperature falls below 40 degrees.
2. Aquastat input: Circuit board has AQ terminal for optional aquastat switch. If the AQ jumper selector is selected to ON, on a call for heat, the blower is energized only after the AQ input is energized when the water temperature reach the selected setpoint temperature.

GENERAL SPECIFICATION

Line Voltage Terminals (120 VAC, 208 VAC, 220 VAC or 240 VAC)

Table 1. Line Voltage Terminals.

Terminal	Description	Purpose / Rating
P1,P33	L1	Line Hot, 120-240 VAC, 50/60 Hz
P2,P3	LINE XFMR	Transformer Primary Leads, 120-240 VAC, 50/60 Hz
P4,P5,P6	N/L2	Line Neutral, 120-240VAC, 50/60 Hz
P7	MTR	Blower Fan Speed Output, 120-240 VAC, 50/60 Hz, 13 FLA (120V)
P8	EH	Electric Heat Signal Input 120-240 VAC,50/60Hz
P9,P10	BLANK	Not in use
P11	PUMP	Circulating Pump Output, 120-240 VAC, 50/60 Hz, 1.5 FLA

Low Voltage Terminals (18-30 VAC)

Table 2. Low Voltage Terminals.

Terminal	Description	Purpose / Rating
P12, P13	24V VALVE	Motorized Valve or Pump Relay Output, 24 VAC, 5A Resistive Load
P14, P15	T T	Dry Contact Boiler On/Off Output, 24 VAC, 5A Resistive Load
P31	ECM	ECM motor Output, 24 VAC
P16,P17, P18	COM	Common, 24 VAC P18 is a part of P30
P19, P20	R	Hot, 24 VAC P19 is a part of P30
P21, P32	R	Hot, 24 VAC
P23	FP	Freeze Protection Input, 24 VAC
P22	AQ	Aquastat Input, 24 VAC
P24	W2	Not in use
P25,26	W1	Thermostat Heat Input, 24 VAC P26 is a part of P29
P27,28	G	Thermostat Fan Input, 24 VAC P27 is a part of P29

Thank you for using www.freepdfconvert.com service!

Only two pages are converted. Please Sign Up to convert all pages.

<https://www.freepdfconvert.com/membership>